

Change Request

To: Chris Barnett
 Crabtree Rohrbaugh & Assoc.
 401 E Winding Hill Rd
 Mechanicsburg, PA 17055
 Ph: 717-458-0272

Number: EC-09
 Date: 5/8/2014
 Job: 13036 EC-Southern Fulton Jr/Sr HS
 Owner Contract #:
 Phone: 717-432-9728

Description: Mag-Lock Fix

Pricing to provide additional power supplies necessary to support the existing Mag-Locks throughout the building.

LABOR

Duration	Hours (H)	Classification	Hourly Rate (BR)	Base Rate Costs (H x BR)
3.00	hrs	PM Time	50.00	\$150.00
4.00	hrs	Supervision and Layout	61.81	\$247.24
35.00	hrs	Electrician	60.81	\$2,128.35
<hr/>				
42.00			Total Wage Rate Cost (TWR)	\$2,525.59

Mandated Burden

	Basis	Rate	Amount	
Social Security	\$2,525.59	7.650 / 100	\$193.21	
State Unemployment Tax	\$2,525.59	10.584 / 100	\$267.31	
Federal Unemployment Tax	\$2,525.59	0.600 / 100	\$15.15	
Worker's Compensation - Project Mgr	\$2,525.59	0.490 / 100	\$0.74	
Worker's Compensation - Electrician	\$2,525.59	4.030 / 100	\$85.77	
Worker's Compensation - All Others	\$2,525.59	8.510 / 100	\$21.04	
Public Liability - All Others	\$2,525.59	1.110 / 1000	\$2.80	
Lobar Fringe	\$42.00	1.050 / HRS	\$44.10	
Vehicle Allowances / Holidays	\$42.00	4.740 / HRS	\$14.22	
<hr/>				
		Total Mandated Burden (TMB)	\$644.34	
			Subtotal:	\$3,169.93
15.00%	Labor Overhead & Profit			\$475.49
			TOTAL LABOR COST:	\$3,645.42

MATERIAL

Quantity (Q)	Units (U)	Description	Unit Cost (MU)	Sales Tax	Amount (Q x MU + Tax)
120.00	ft	#12 THHN solid copper wire	0.15	\$1.08	\$19.08
30.00	ft	#12/2 MC Cable	0.50	\$0.90	\$15.90
1500.00	ft	#14/2 Cable	0.25	\$22.50	\$397.50
2.00	es	20A duplex receptacles (2 UNIT PRICES)	0.00	\$0.00	\$0.00
1.00	ea	20A single pole breaker	35.00	\$0.00	\$35.00
30.00	ft	3/4" EMT + boxes and fittings	1.26	\$2.27	\$40.07

Change Request

EC-09

40.00	ea	J-Hooks	2.45	\$5.88	\$103.88
2.00	ea	Kerri KPS11 Power Supplies	497.35	\$0.00	\$994.70
			Subtotal:	\$32.63	\$1,606.13
15.00%			Material Overhead & Profit		\$240.92
					TOTAL MATERIAL COST:
					\$1,847.05

Summary

Labor		\$3,645.42
Materials		\$1,847.05
Subtotal:		\$5,492.47

GENERAL ADD-ONS

Rate		Amount
1.50%	Bond	\$82.39
Subtotal Add-ons:		\$82.39

The total Amount to provide this work is\$5,574.86

Only the work specifically detailed and priced above is included in this proposal. Any other work required is not included. This proposal is valid for fifteen (15) calendar days. We can proceed with this additional work as soon as written authorization as provided by the Contract documents is received. This additional work will require a 0 day(s) time extension.

Any costs incurred as a result of a time extension will be compiled and submitted for reimbursement. It is expressly understood between the Owner and Lobar, Inc. that the costs reflected in this additional work compensate Lobar, Inc. for the material and labor costs, including appropriate markups for overhead and profit to perform the described work. Lobar, Inc. expressly reserves its right to submit a claim pursuant to the Contract documents to recover costs associated with any delay, inefficiency or acceleration associated with the performance of the described work.

If you have any questions, please contact me at Ph: 717-432-9728

Thank you

Jonathan C. Lawrence

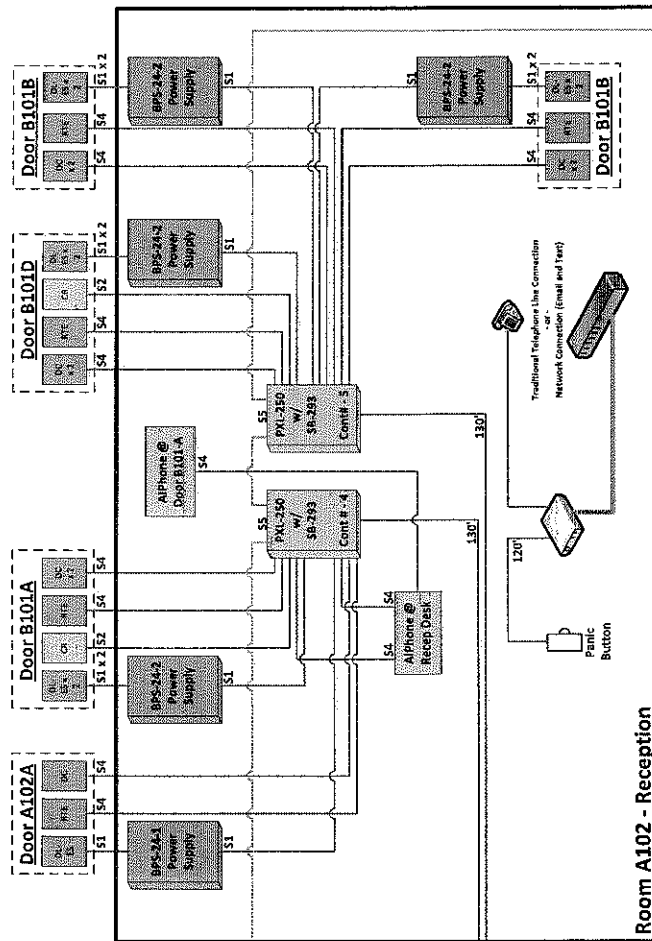

Room A102 - Reception

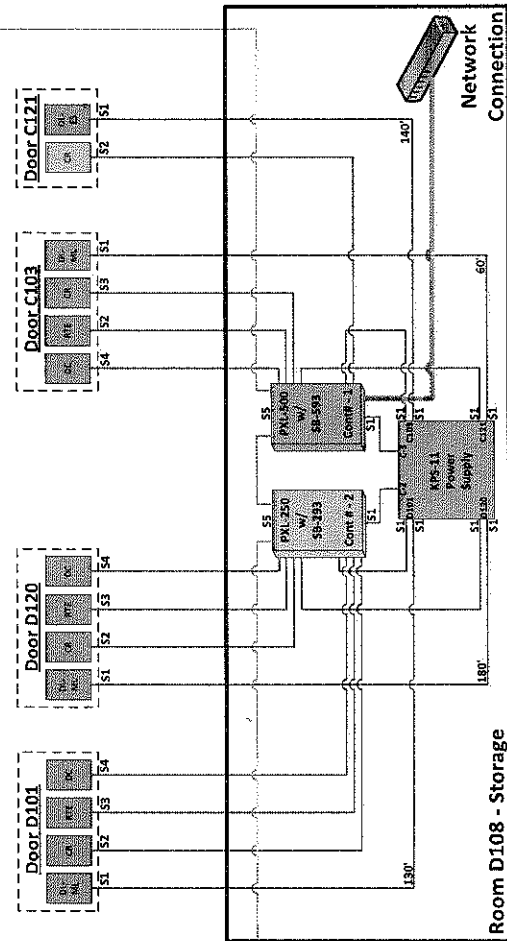

Room D108 - Storage

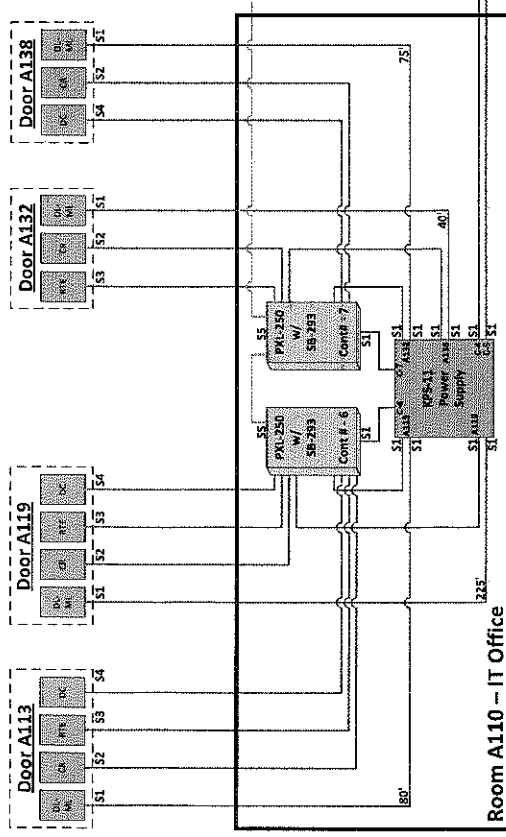

Room A110 - IT Office

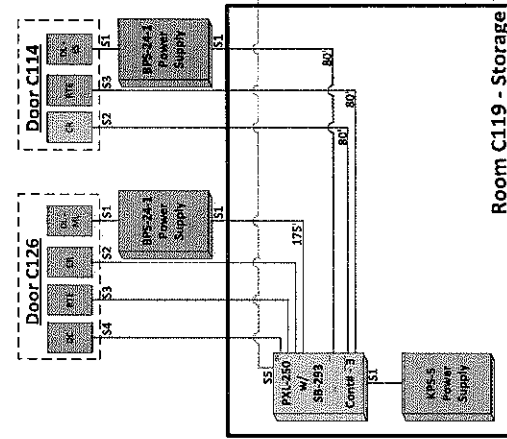

Room C119 - Storage

DEVICE & COLOR LEGEND	
CR	Card Reader
DC	Door Contact / Position Switch
RTE	Request to Exit
DL-ES	Door Lock - Electric Strike
DL-ML	Door Lock - Mag Lock
---	Existing Device to Remain / No Change
---	Existing Device Relocated
---	New Device Via Original Contract
---	New Device Via Redesign Proposal

WIRE & COLOR LEGEND	
Type S1	14/2 Stranded Non-Shielded
Type S2	22/6 Stranded Non-Shielded
Type S3	22/4 Stranded Non-Shielded
Type S4	22/2 Stranded Non-Shielded
Type S5	24/2 Stranded Shielded Data Wire
---	Existing Wire
---	New Wire
---	Controller Interconnect Wire
---	Network Cable

Southern Fulton JR./SR. High School
Proposed Access Control Configuration